

# Huawei FusionServer 5288 V5

## White Paper

**Issue** 04  
**Date** 2018-10-30



**Copyright © Huawei Technologies Co., Ltd. 2018. All rights reserved.**

No part of this document may be reproduced or transmitted in any form or by any means without prior written consent of Huawei Technologies Co., Ltd.

## **Trademarks and Permissions**



HUAWEI and other Huawei trademarks are trademarks of Huawei Technologies Co., Ltd.

All other trademarks and trade names mentioned in this document are the property of their respective holders.

## **Notice**

The purchased products, services and features are stipulated by the contract made between Huawei and the customer. All or part of the products, services and features described in this document may not be within the purchase scope or the usage scope. Unless otherwise specified in the contract, all statements, information, and recommendations in this document are provided "AS IS" without warranties, guarantees or representations of any kind, either express or implied.

The information in this document is subject to change without notice. Every effort has been made in the preparation of this document to ensure accuracy of the contents, but all statements, information, and recommendations in this document do not constitute a warranty of any kind, express or implied.

## **Huawei Technologies Co., Ltd.**

Address: Huawei Industrial Base  
Bantian, Longgang  
Shenzhen 518129  
People's Republic of China

Website: <http://e.huawei.com>

# About This Document

## Purpose

This document describes the 5288 V5 in terms of its appearance, performance parameters, and component compatibility to help users have a profound understanding of the 5288 V5.





## Intended Audience


This document is intended for:

- Huawei presales engineers
- Channel partner presales engineers
- Enterprise presales engineers

## Symbol Conventions

The symbols that may be found in this document are defined as follows.

Symbol	Description
	Indicates an imminently hazardous situation which, if not avoided, will result in death or serious injury.
	Indicates a potentially hazardous situation which, if not avoided, could result in death or serious injury.
	Indicates a potentially hazardous situation which, if not avoided, may result in minor or moderate injury.
	Indicates a potentially hazardous situation which, if not avoided, could result in equipment damage, data loss, performance deterioration, or unanticipated results. NOTICE is used to address practices not related to personal injury.

Symbol	Description
 <b>NOTE</b>	<p>Calls attention to important information, best practices and tips.</p> <p>NOTE is used to address information not related to personal injury, equipment damage, and environment deterioration.</p>

## Change History

Changes between document issues are cumulative. The latest document issue contains all the changes made in earlier issues.

### Issue 04 (2018-10-30)

This issue is the fourth official release.

Mode	Description
New	Added description about built-in drives. For details, see <a href="#">6.3 Storage</a> .

### Issue 03 (2018-09-06)

This issue is the third official release.

Mode	Change Description
New	Added PCIe GPU configuration rules. For details, see <a href="#">4.4 Riser Cards and PCIe Slots</a> .

### Issue 02 (2018-05-14)

This issue is the second official release.

Mode	Change Description
Modified	Modified video card description. For details, see <a href="#">Table 5-1</a> .

### Issue 01 (2018-04-11)

This issue is the first official release.

---

# Contents

---

<b>About This Document.....</b>	<b>ii</b>
<b>1 Overview.....</b>	<b>1</b>
<b>2 Features.....</b>	<b>2</b>
<b>3 Logical Structure.....</b>	<b>5</b>
<b>4 Hardware Description.....</b>	<b>7</b>
4.1 Appearance.....	7
4.2 Ports.....	9
4.3 Indicators and Buttons.....	13
4.4 Riser Cards and PCIe Slots.....	20
4.5 Physical Structure.....	28
<b>5 Product Specifications.....</b>	<b>30</b>
5.1 Technical Specifications.....	30
5.2 Physical and Environmental Specifications.....	35
<b>6 Component Compatibility.....</b>	<b>40</b>
6.1 CPU.....	40
6.2 Memory.....	40
6.3 Storage.....	46
6.4 I/O Expansion.....	49
6.5 PSU.....	49
6.6 OS and Software Support.....	50
<b>7 System Management.....</b>	<b>51</b>
<b>8 Warranty.....</b>	<b>53</b>
<b>9 Certifications.....</b>	<b>54</b>
<b>10 References.....</b>	<b>56</b>

# 1 Overview

---

The Huawei FusionServer 5288 V5 is a 4U dual-socket or single-socket rack server that adopts efficient design to ensure excellent computing performance and large-capacity local storage with elastic scalability. Marked H52H-05 on the nameplate, the 5288 V5 is ideal for cold data storage, video surveillance, cloud storage, and Big Data, and can be widely used in a variety of industries, such as media and entertainment, finance, and public security.

**Figure 1-1** Appearance



# 2 Features

## Performance and Scalability

The 5288 V5 offers the following features to boost performance and improve scalability:

- Intel® Xeon® Scalable processors ensure high processing performance by providing up to 28 cores, 3.6 GHz frequency, 38.5 MB L3 cache, and two 10.4 GT/s Ultra Path Interconnect (UPI) links between processors.
  - Each 5288 V5 supports two processors with 56 cores and 112 threads to maximize the concurrent execution of multithreaded applications.
  - Intel® Xeon® Scalable processors support L2 cache. Each core exclusively uses 1 MB L2 cache and at least 1.375 MB L3 cache.
  - Intel® Turbo Boost Technology 2.0 enables processor cores to run at maximum speeds during peak hours by temporarily going beyond the processor thermal design power (TDP).
  - Intel® Hyper-Threading Technology enables each processor core to run up to two threads, improving parallel computation capability.
  - Intel® Virtualization Technology integrates hardware-level virtualization functions to allow OS vendors to better use hardware to address virtualization workloads.
- Twenty-four DDR4 error checking and correcting (ECC) RDIMMs or load-reduced DIMMs (LRDIMMs) provide a maximum memory speed of 2666 MT/s and a maximum memory capacity of 3,072 GB, featuring high speed and availability. The maximum memory bandwidth is 249.9375 GB/s in theory.
- The 5288 V5 supports flexible drive configurations and provides elastic and scalable memory capacities to satisfy storage capacity and upgrade requirements.
- Intel® Advanced Vector Extensions 2.0 (AVX-512) improves floating-point computing performance for computing-intensive applications.
- The I/O performance of pure SSDs is higher than that of mixed configuration of SSDs and HDDs and 100 times that of pure HDDs.
- The 5288 V5 supports various LAN on motherboard (LOM) and flexible NICs to provide rich network ports.
- The 5288 V5 supports up to eight PCIe 3.0 slots.
- The Intel® Xeon® Scalable processors incorporate the PCIe 3.0 controller using the Intel Integrated I/O. This remarkably shortens I/O latency and enhances overall system performance.

## Availability and Serviceability

The 5288 V5 provides the following features to improve availability and serviceability:

- The 5288 V5 uses carrier-class components and follows the engineering process, which dramatically improves system reliability.
- The 5288 V5 uses hot-swappable SAS/SATA drives or NVMe SSDs. It supports redundant array of independent disks (RAID) 0, 1, 1E, 10, 5, 50, 6, and 60 and offers RAID cache. A supercapacitor is used to protect RAID cache data from power failures.
- SSDs offer better reliability than HDDs, prolonging system uptime.
- The web user interface (WebUI) of the Intelligent Baseboard Management Controller (iBMC) and the UID and HLY LEDs and fault diagnosis LED on the panel help technical support personnel promptly obtain the status of key components and locate failed (or failing) components. This simplifies servicing, accelerates troubleshooting, and helps improve system availability.
- The iBMC monitors system parameters in real time, triggers alarms, and performs recovery actions in case of failures, minimizing system downtime.
- Huawei provides a three-year warranty for parts replacement and limited onsite repair for the servers used in China. Huawei provides a 10-hour-a-day, 5-day-a-week support program. Service requests will be handled the next business day. Optional service upgrades are available.
- Huawei provides a three-year warranty for parts replacement and repair for the servers used outside China. Huawei provides a 9-hour-a-day, 5-day-a-week support program. Service requests will be handled the next business day. Huawei delivers the repaired or new parts within 45 calendar days after receiving the defective parts.

## Manageability and Security

The 5288 V5 provides the following features to enhance manageability and security:

- The built-in iBMC module monitors server operating status and provides remote management.
- The Network Controller Sideband Interface (NC-SI) feature enables a network port to function as a management network port and a service port, which maximizes the return on investment (ROI) for customers. NC-SI is disabled by default. You can enable it on the iBMC WebUI or in the BIOS.
- The integrated industry-standard Unified Extensible Firmware Interface (UEFI) increases setup, configuration, and update efficiency, and simplifies fault handling.
- The front bezel in the server chassis is locked to ensure local data security and reliability.
- The Intel® Advanced Encryption Standard–New Instructions (AES NI) support faster and stronger encryption.
- The Intel® Execute Disable Bit (EDB) function prevents certain types of malicious buffer overflow attacks when working with a supported OS.
- The Intel® Trusted Execution technology provides enhanced security by using hardware-based defense against malicious software attacks, allowing an application to run in an isolated space from all other applications running on the OS.



 **NOTE**

The service network port supporting NC-SI has the following features:

- The service network port can be bound to a network port (host network port 1 by default) on a flexible or standard NIC.
- The service network port allows you to enable, disable, and configure a VLAN ID. A VLAN ID is disabled by default, and the default VLAN ID is 0.
- The service network port supports IPv4 and IPv6 addresses. You can set an IP address, subnet mask, default gateway, and IPv6 address prefix length for the service network port.

## Energy Efficiency

The 5288 V5 offers the following features to save energy:

- The 5288 V5 supports 80 Plus Platinum power supply units (PSUs). The PSUs provide 94% power efficiency at 50% loads.
- The 5288 V5 supports active-standby power supplies and high-voltage DC (HVDC), improving power supply efficiency.
- Efficient VRD PSUs reduce the loss in DC/DC power conversion.
- The 5288 V5 supports area-based and intelligent fan speed adjustment, Proportional-Integral-Derivative (PID) speed adjustment, and intelligent processor frequency adjustment, reducing power consumption.
- The improved thermal design with energy-efficient fans ensures optimal heat dissipation and reduces system power consumption.
- The 5288 V5 supports power capping and power control.
- Drives are not powered on simultaneously, which reduces the server startup power consumption.
- The Intel® Intelligent Power Capability allows a single processor to be powered on or off based on site requirements.
- Low-voltage Intel® Xeon® Scalable processors consume less energy and apply to data centers and telecommunication environments that have power and thermal limitations.
- SSDs consume 80% less power than HDDs.

## Support for Customization

The 5288 V5 is a Huawei proprietary server. Huawei also provides customized development in a timely manner.



- The Huawei Hi1710 management chip provides a VGA port, management network port, and debugging serial port.

# 4 Hardware Description

## 4.1 Appearance

### 4.2 Ports

### 4.3 Indicators and Buttons

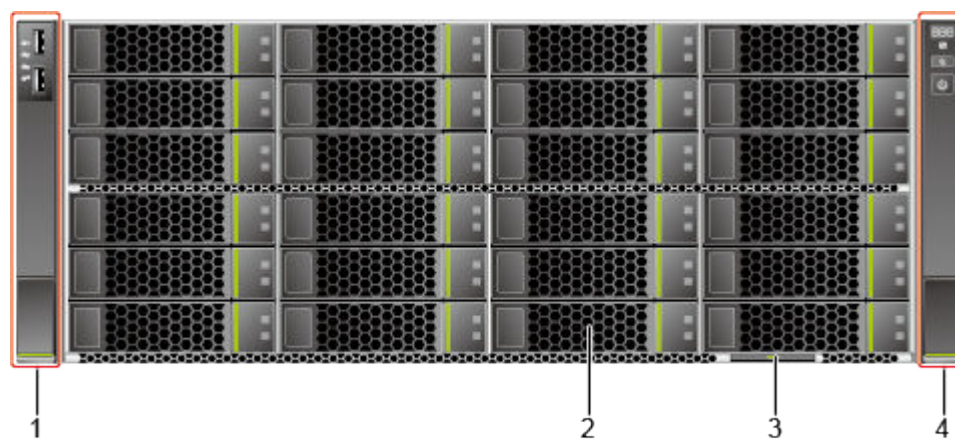
### 4.4 Riser Cards and PCIe Slots

### 4.5 Physical Structure

## 4.1 Appearance

### Front Panel

Figure 4-1 Front panel



- |   |                              |   |                    |
|---|------------------------------|---|--------------------|
| 1 | Left mounting ear            | 2 | Drives             |
| 3 | Label plate with an SN label | 4 | Right mounting ear |

### SN

The SN on the label is a string that uniquely identifies a server. The SN is required when you contact Huawei technical support.

Figure 4-2 shows the SN format.

Figure 4-2 SN example

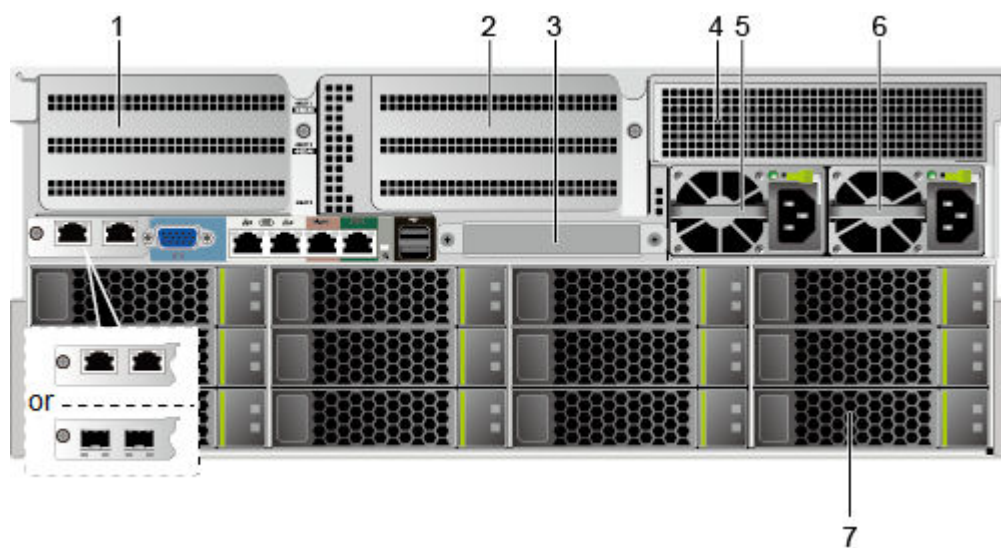


Table 4-1 SN description

No.	Description
1	SN ID (two digits), which is 21 fixedly.
2	Material identification code (eight digits), that is, processing code.
3	Vendor code (two digits). The code is 10 for Huawei and other value for outsourcing vendors.
4	<p>Year and month (two characters).</p> <ul style="list-style-type: none"> <li>The first character indicates the year. The digits 1 to 9 indicate 2001 to 2009, the letters A to H indicate 2010 to 2017, the letters J to N indicate 2018 to 2022, and the letters P to Y indicate 2023 to 2032.</li> </ul> <p><b>NOTE</b> The years from 2010 are represented by upper-case letters excluding I, O, and Z because the three letters are similar to the digits 1, 0, and 2.</p> <ul style="list-style-type: none"> <li>The second character indicates the month. The digits 1 to 9 indicate January to September, and the letters A to C indicate October to December.</li> </ul>
5	Serial number (six digits).
6	RoHS compliance (one character). Y indicates environmental protection processing.
7	Internal model, that is, product name.

## Rear Panel

Figure 4-3 Rear panel



- |   |                           |   |              |
|---|---------------------------|---|--------------|
| 1 | I/O module 1              | 2 | I/O module 2 |
| 3 | Flexible NIC (optional)   | 4 | I/O module 3 |
| 5 | Power supply unit (PSU) 1 | 6 | PSU 2        |
| 7 | Rear drives               | - | -            |

**NOTE**

I/O modules 1, 2, and 3 can be drive modules or riser card modules. The preceding figure is for reference only.

## 4.2 Ports

### Front Panel

Figure 4-4 Ports on the front panel



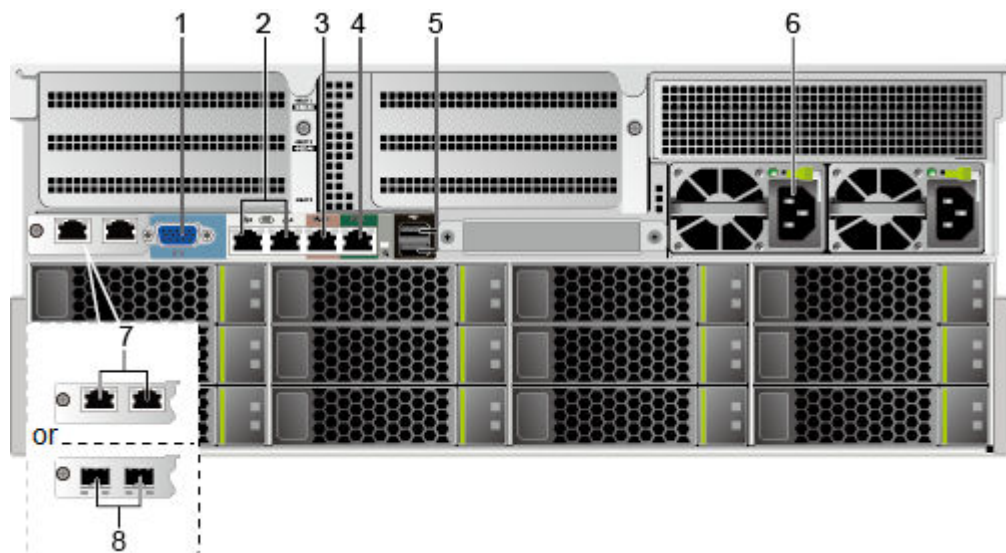
- |   |               |   |   |
|---|---------------|---|---|
| 1 | USB 2.0 ports | - | - |
|---|---------------|---|---|

**Table 4-2** Description of ports on the front panel

Port	Type	Description
USB port	USB 2.0	The USB ports allow USB devices to be connected to the server. <b>NOTE</b> Before connecting an external USB device, check that the USB device functions properly. The server may operate abnormally if an abnormal USB device is connected.

## Rear Panel

**Figure 4-5** Ports on the rear panel



- |   |                         |   |                     |
|---|-------------------------|---|---------------------|
| 1 | VGA port                | 2 | GE electrical ports |
| 3 | Management network port | 4 | Serial port         |
| 5 | USB 3.0 ports           | 6 | PSU sockets         |
| 7 | 10GE electrical ports   | 8 | 10GE optical ports  |

**Table 4-3** Description of ports on the rear panel

Port	Type	Quantity	Description
10GE electrical port	10GBASE-T	2	The mainboard provides two 10GE electrical ports or two 10GE optical ports for you to select.
10GE optical port	10GE SFP+	2	

Port	Type	Quantity	Description
VGA port	DB15	1	The VGA port is used to connect a terminal, such as a monitor or KVM.
GE electrical port	1000BASE-T	2	Server service network port.
Serial port	RJ45	1	The serial port is used as the system serial port by default. You can set it as the iBMC serial port by using the iBMC command. This port is used for debugging.
Management network port	1000BASE-T	1	The 1000 Mbit/s Ethernet port is used for server management, and GE network ports are provided to support 100/1000 Mbit/s auto-negotiation.
USB port	USB 3.0	2	The USB ports allow USB devices to be connected to the server. <b>NOTICE</b> Before connecting an external USB device, check that the USB device functions properly. The server may operate abnormally if an abnormal USB device is connected.
PSU socket	—	1 or 2	Determine the quantity of PSUs based on actual requirements, but ensure that the rated power of the PSUs is greater than that of the server. When one PSU is used, <b>Predicted PSU Status</b> cannot be set to <b>Active/Standby</b> .

**Table 4-4** LOM port description

LOM Port	Chip Model	Rate Negotiation Mode	Supported Rate	Not Supported Rate
10GE optical port	X722	Auto-negotiation 10000 Mbit/s (full duplex)	10000 Mbit/s	10/100/1000 Mbit/s
10GE electrical port		Auto-negotiation 1000 Mbit/s (full duplex)	1000 Mbit/s	10/100 Mbit/s



LOM Port	Chip Model	Rate Negotiation Mode	Supported Rate	Not Supported Rate
		Auto-negotiation 10000 Mbit/s (full duplex)	10000 Mbit/s	10/100 Mbit/s
GE electrical port		Auto-negotiation 1000 Mbit/s (full duplex)	1000 Mbit/s	10/100 Mbit/s
<p><b>NOTE</b></p> <ul style="list-style-type: none"> <li>● The LOM ports do not support forcible rates.</li> <li>● The GE LOM electrical port does not support SR-IOV.</li> <li>● The 10GE electrical ports and GE electrical ports provided by the X722 NIC does not support interconnection with the PoE power supply device (for example, the PoE switch with the POE function enabled). If the X722 NIC is forcibly connected, the link communication may be abnormal or the NIC may be damaged.</li> <li>● <a href="#">Table 4-5</a> lists the cables and optical modules supported by the LOM ports.</li> </ul>				

**Table 4-5** Cables and optical modules

Huawei Part Number	Description
02318169	Switch Products,LE0M0XSM88,Optical Transceiver,SFP +,10G,Multi-mode Module(850nm,0.3km,LC)
02318170	Switch Products,LE0M0XS1DD,Optical Transceiver,SFP +,10G,Single-mode Module(1310nm,10km,LC)
04050233	High Speed Cable,10G Passive SFP+ Cable,1m,(SFP +20M),(CC2P0.254B),(SFP+20M),LSFRZH For Indoor,ETH 10GbE,Y
04050185	High Speed Cable,10G SFP+ High Speed Cable,3m,SFP +20M,CC2P0.254B(S),SFP+20M,LSFRZH For Indoor,ETH 10GbE,LSZH

## 4.3 Indicators and Buttons



### Front Panel





Figure 4-6 Indicators and buttons on the front panel



- |   |                        |
|---|------------------------|
| 1 LOM port connection status indicators (1 to 4 from top to down) | 2 Fault diagnosis LED  |
| 3 Health indicator  | 4 UID button/indicator |
| 5 Power button/indicator  | - -                    |

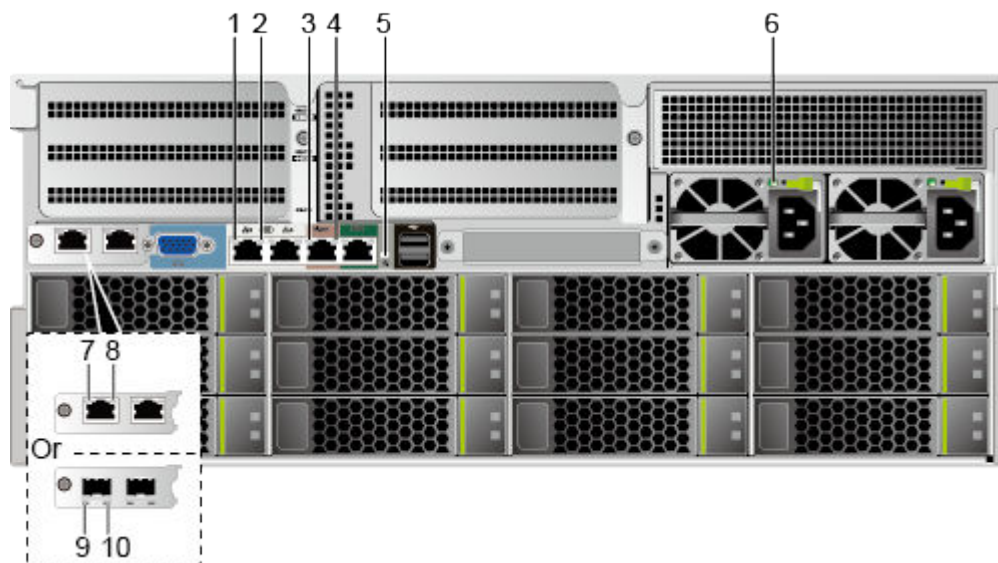
Table 4-6 Description of indicators and buttons on the front panel

Silk Screen	Indicator and Button	State Description
	Fault diagnosis LED	<ul style="list-style-type: none"> <li>● ---: The server is operating normally.</li> <li>● Fault code: A server component is faulty. For details about fault code, see the <a href="#">Huawei Rack Server iBMC Alarm Handling</a>.</li> </ul>
	Power button/indicator	<p>Power indicator</p> <ul style="list-style-type: none"> <li>● Steady yellow: The server is ready to power on.</li> <li>● Steady green: The server is properly powered on.</li> <li>● Blinking yellow: The iBMC is starting.</li> <li>● Off: The server is not connected to a power source.</li> </ul> <p>Power button</p> <ul style="list-style-type: none"> <li>● When the server is powered on, you can press this button to shut down the OS.</li> <li>● When the server is powered on, holding down this button for 6 seconds will power off the server.</li> <li>● When the server is ready to be powered on, you can press this button to start the server.</li> </ul>

Silk Screen	Indicator and Button	State Description
	UID button/ indicator	The UID button/indicator helps identify and locate a server. You can turn on or off the UID indicator by pressing the UID button or remotely running a command on the iBMC CLI.  UID indicator <ul style="list-style-type: none"> <li>● Steady blue/Blinking blue: The server is being located.</li> <li>● Off: The server is not being located.</li> </ul> UID button <ul style="list-style-type: none"> <li>● You can press this button to turn on or off the UID indicator.</li> <li>● You can press and hold down this button for 4 to 6 seconds to reset the iBMC.</li> </ul>
	Health indicator	<ul style="list-style-type: none"> <li>● Steady green: The server is operating properly.</li> <li>● Blinking red at 1 Hz: A major alarm has been generated on the server.</li> <li>● Blinking red at 5 Hz: A critical alarm has been generated on the server.</li> </ul>
	NMI button	The NMI button triggers a server to generate a non-maskable interrupt. You can press this button or control it remotely through the iBMC WebUI.  <b>NOTICE</b> <ul style="list-style-type: none"> <li>● Press the NMI button only when the OS is abnormal. Do not press this button when the server is operating properly.</li> <li>● Before pressing the NMI button, ensure that the OS has the handler for NMI interrupts. Otherwise, the OS may crash. Exercise caution when pressing this button.</li> </ul>
	LOM port connection status indicator	Each indicator shows the status of an Ethernet port on the LOM. <ul style="list-style-type: none"> <li>● Steady green: The network port is properly connected.</li> <li>● Off: The network port is not in use or has failed.</li> </ul> <b>NOTE</b> <ul style="list-style-type: none"> <li>● The indicators correspond to two 10GE and two GE network ports on the mainboard.</li> <li>● The LOM has a standby power supply and is not powered off after the service system is powered off. If the network ports are properly connected to other working network devices, the network ports are still connected and the indicators are on.</li> </ul>

## Rear Panel

**Figure 4-7** Indicators on the rear panel



- |  |  |
|--|--|
| 1 Data transmission status indicator                             | 2 Connection status indicator                                    |
| 3 Data transmission status indicator                             | 4 Connection status indicator                                    |
| 5 UID indicator  | 6 PSU indicator  |
| 7 Transmission rate indicator                                    | 8 Connection status indicator/Data transmission status indicator |
| 9 Connection status indicator/Data transmission status indicator | 10 Transmission rate indicator                                   |

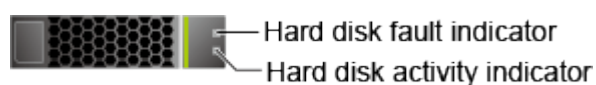
**Table 4-7** Description of indicators on the rear panel

Indicator		State Description
10GE electrical port	Transmission rate indicator	<ul style="list-style-type: none"> <li>● Steady green: The data transmission rate is 10 Gbit/s.</li> <li>● Steady yellow: The data transmission rate is 1 Gbit/s.</li> <li>● Off: The network port is not connected.</li> </ul>
	Connection status indicator/Data transmission status indicator	<ul style="list-style-type: none"> <li>● Steady green: The network port is properly connected.</li> <li>● Blinking green: Data is being transmitted.</li> <li>● Off: The network port is not connected.</li> </ul>
10GE optical port	Transmission rate indicator	<ul style="list-style-type: none"> <li>● Steady green: The data transmission rate is 10 Gbit/s.</li> <li>● Steady yellow: The data transmission rate is lower than 10 Gbit/s.</li> <li>● Off: The network port is not connected.</li> </ul>

Indicator		State Description
	Connection status indicator/Data transmission status indicator	<ul style="list-style-type: none"> <li>● Steady green: The network port is properly connected.</li> <li>● Blinking green: Data is being transmitted.</li> <li>● Off: The network port is not connected.</li> </ul>
GE electrical port	Connection status indicator	<ul style="list-style-type: none"> <li>● Steady green: The network port is properly connected.</li> <li>● Off: The network port is not connected.</li> </ul>
	Data transmission status indicator	<ul style="list-style-type: none"> <li>● Blinking yellow: Data is being transmitted.</li> <li>● Off: No data is being transmitted.</li> </ul>
UID indicator		<p>The UID indicator helps identify and locate a server. You can turn on or off the UID indicator by pressing the UID button or remotely running a command on the iBMC CLI.</p> <ul style="list-style-type: none"> <li>● Steady blue/Blinking blue: The server is being located.</li> <li>● Off: The server is not being located.</li> </ul>
PSU indicator		<ul style="list-style-type: none"> <li>● Steady green: The power input and output are normal.</li> <li>● Steady orange: The input is normal, but no power output is supplied due to overheat protection, overcurrent protection, short circuit protection, output overvoltage protection, or some component failures.</li> <li>● Blinking green at 4 Hz: under online upgrade.</li> <li>● Blinking green at 1 Hz: <ul style="list-style-type: none"> <li>- The input is normal, the server is standby, and the PSU is in MV6 mode. (The output voltage is 6.7 V.)</li> <li>- The input is overvoltage or undervoltage.</li> <li>- The PSU is in deep hibernation mode.</li> </ul> </li> <li>● Off: No AC power is supplied.</li> </ul>

## SAS/SATA Drive Indicators

Figure 4-8 SAS/SATA drive indicators



**Table 4-8** Description of SAS/SATA drive indicators

Indicator	State Description
Drive fault indicator	<ul style="list-style-type: none"> <li>● Steady yellow: The drive is faulty or the status of a member disk in a RAID array is abnormal.</li> <li>● Blinking yellow: The server is locating the drive or rebuilding RAID.</li> <li>● Off: The drive is operating normally.</li> </ul>
Drive activity indicator	<ul style="list-style-type: none"> <li>● Steady green: The drive is inactive.</li> <li>● Blinking green: Data is being read from or written to the drive, or synchronized between drives.</li> <li>● Off: The drive is faulty or not detected.</li> </ul>

## NVMe SSD Indicators

**Figure 4-9** NVMe SSD indicators



**Table 4-9** NVMe SSD indicators

Green Indicator	Yellow Indicator	State Description
Off	Off	The NVMe SSD cannot be detected.
Steady green	Off	The NVMe SSD is detected and working properly.
Blinking green (2 Hz)	Off	Data is being read from or written to the NVMe SSD.
Off	Blinking yellow (2 Hz)	The NVMe SSD is being located or hot-swapped.
Off	Blinking yellow (0.5 Hz)	The NVMe SSD completes the hot removal process and is removable.
Steady green or off	Steady yellow	The NVMe SSD is faulty.

## Flexible NIC Indicators

Supported flexible NICs include:

- SM211 (chip: i350) with two GE electrical ports
- SM210 (chip: 5719)/SM212 (chip: i350) with four GE electrical ports

- SM233 (chip: X540) with two 10GE electrical ports
- SM252 (chip: CX3) with one 56G IB optical port
- SM251 (chip: CX3) with two 56G IB optical ports
- SM380 (chip: CX4) with two 25GE optical ports

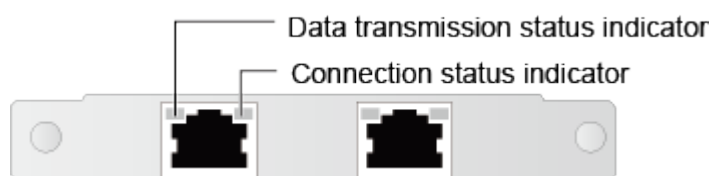
**NOTICE**

The electrical ports of the SM211, SM212, and SM233 flexible NICs do not support interconnection with the PoE power supply device (for example, the PoE switch with the POE function enabled). If such a NIC is forcibly connected, the link communication may be abnormal or the NIC may be damaged.

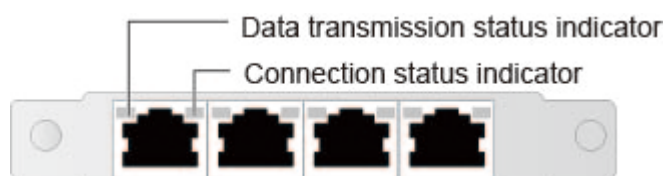
Use the [Huawei Server Compatibility Checker](#) to obtain the details about the flexible NICs.

The following figures show the indicators on these flexible NICs.

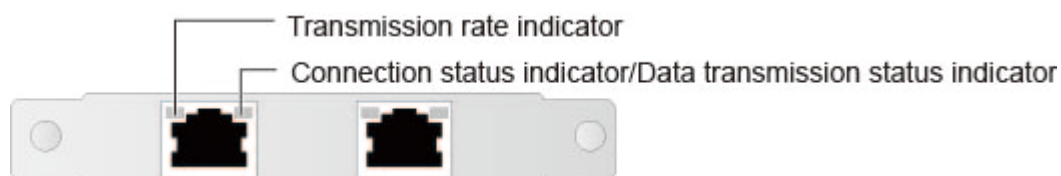
**Figure 4-10** SM211 with two GE electrical ports



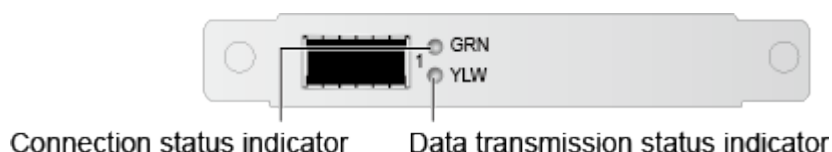
**Figure 4-11** SM210/SM212 with four GE electrical ports



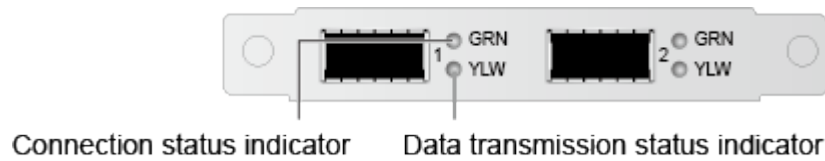
**Figure 4-12** SM233 with two 10GE electrical ports



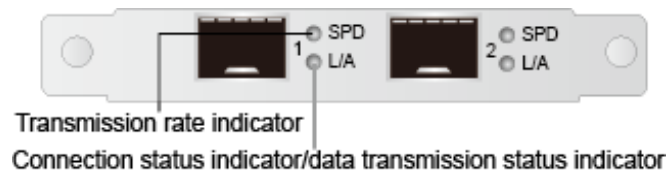
**Figure 4-13** SM252 with one 56G IB optical port



**Figure 4-14** SM251 with two 56G IB optical ports



**Figure 4-15** SM380 with two 25GE optical ports



**Table 4-10** Description of flexible NIC indicators

NIC Type	Indicator	State Description
<ul style="list-style-type: none"> <li>Flexible NIC with two GE electrical ports</li> <li>Flexible NIC with four GE electrical ports</li> </ul>	Data transmission status indicator	<ul style="list-style-type: none"> <li>Blinking yellow: Data is being transmitted.</li> <li>Off: No data is being transmitted.</li> </ul>
	Connection status indicator	<ul style="list-style-type: none"> <li>Steady green: The network port is properly connected.</li> <li>Off: The network port is not connected.</li> </ul>
Flexible NIC with two 10GE electrical ports	Transmission rate indicator	<ul style="list-style-type: none"> <li>Steady green: The data transmission rate is 10 Gbit/s.</li> <li>Steady yellow: The data transmission rate is 1 Gbit/s.</li> <li>Off: The data transmission rate is 10/100 Mbit/s.</li> </ul>
	Connection status indicator/Data transmission status indicator	<ul style="list-style-type: none"> <li>Steady green: The network port is properly connected.</li> <li>Blinking green: Data is being transmitted.</li> <li>Off: No data is being transmitted or the network port is not connected.</li> </ul>
<ul style="list-style-type: none"> <li>Flexible NIC with one 56G IB optical port</li> <li>Flexible NIC with two 56G IB optical ports</li> </ul>	Data transmission status indicator	<ul style="list-style-type: none"> <li>Steady yellow: The logical link is normal but no data is being transmitted.</li> <li>Blinking yellow: Data is being transmitted.</li> <li>Off: No logical link is set up.</li> </ul>

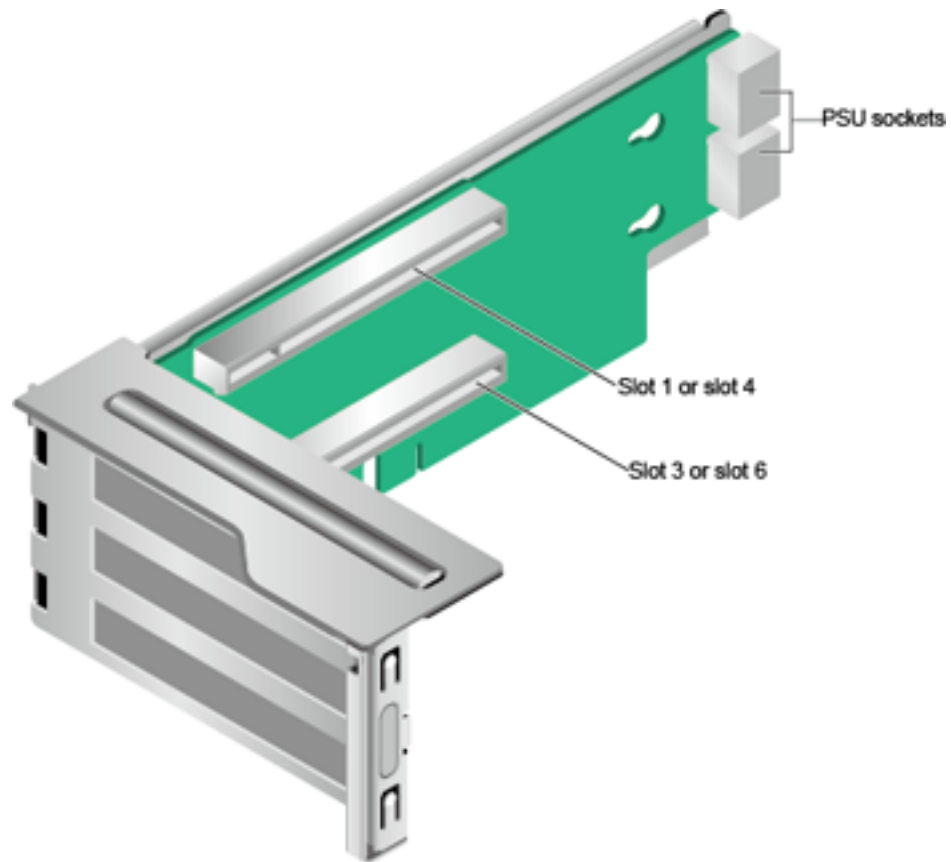


NIC Type	Indicator	State Description
	Connection status indicator	<ul style="list-style-type: none"> <li>● Steady green: The physical link is normal.</li> <li>● Blinking green: The physical link is abnormal.</li> <li>● Off: No physical link is set up.</li> </ul>
Flexible NIC with two 25GE optical ports	Transmission rate indicator	<ul style="list-style-type: none"> <li>● Steady green: The data transmission rate is 25 Gbit/s.</li> <li>● Steady yellow: The data transmission rate is 10 Gbit/s.</li> <li>● Off: The network port is not connected.</li> </ul>
	Connection status indicator or data transmission status indicator	<ul style="list-style-type: none"> <li>● Steady green: The network port is properly connected.</li> <li>● Blinking green: Data is being transmitted.</li> <li>● Off: The network port is not connected.</li> </ul>

## 4.4 Riser Cards and PCIe Slots

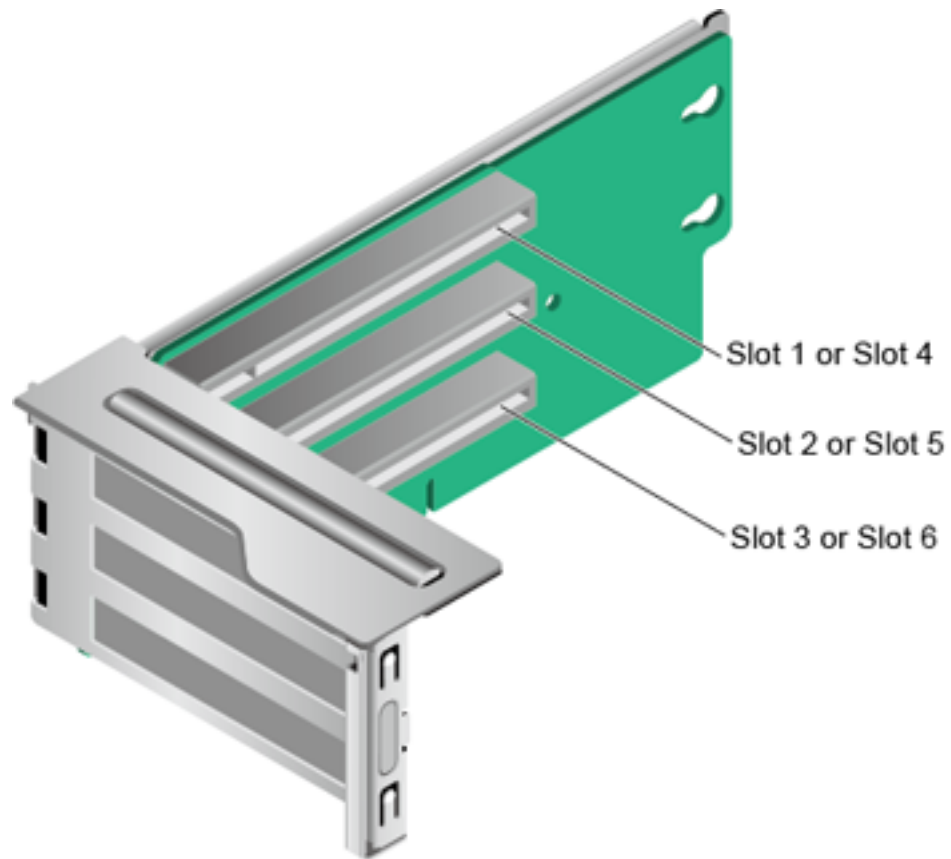
[Figure 4-16](#), [Figure 4-17](#), [Figure 4-18](#), [Figure 4-19](#), [Figure 4-20](#), and [Figure 4-21](#) show the riser cards supported by the server.

**Figure 4-16** Riser card 1 (universal)



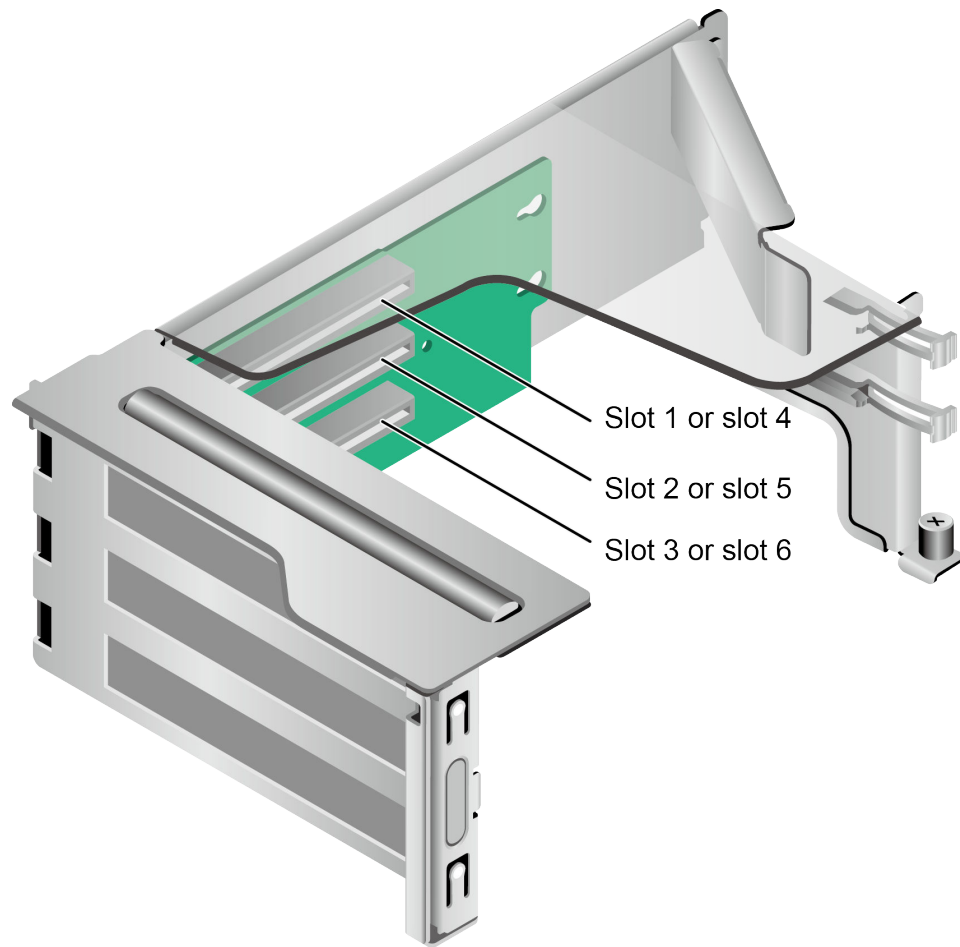
When installed in I/O module 1, this riser card provides slots 1 and 3. When installed in I/O module 2, this riser card provides slots 4 and 6.

**Figure 4-17** Riser card 2 (universal)



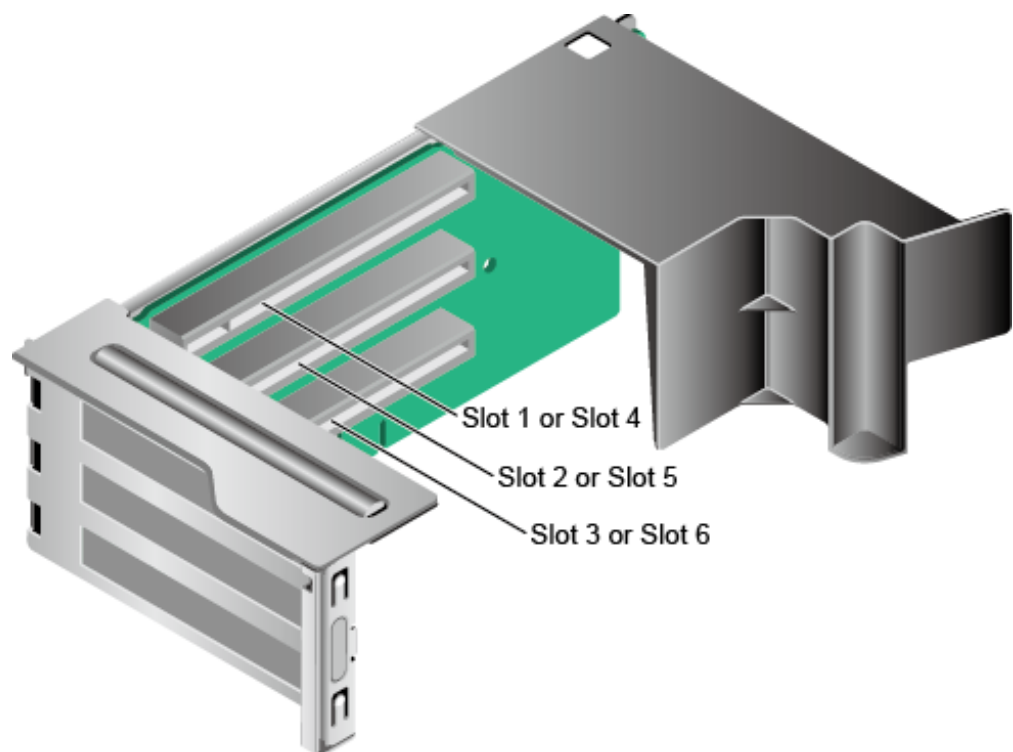
When installed in I/O module 1, this riser card provides slots 1 to 3. When installed in I/O module 2, this riser card provides slots 4 to 6.

**Figure 4-18** Riser card 3 (dedicated for PCIe SSD cards)



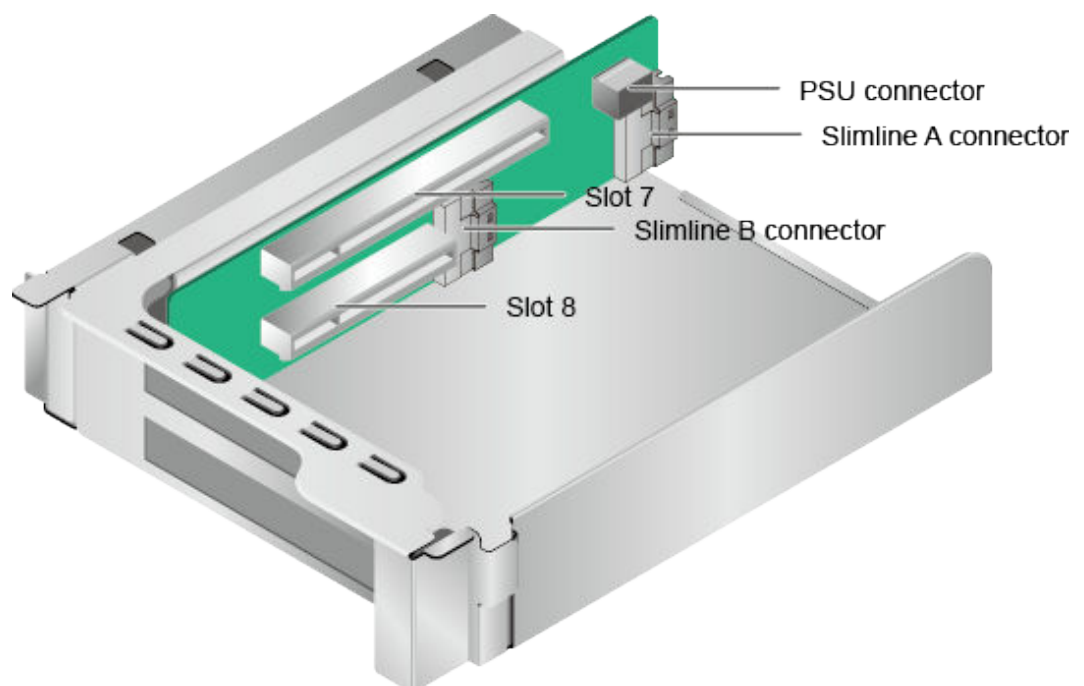
When installed in I/O module 1, this riser card provides slots 1 to 3. When installed in I/O module 2, this riser card provides slots 4 to 6.

**Figure 4-19** Riser card 4 (dedicated for P4 GPUs)

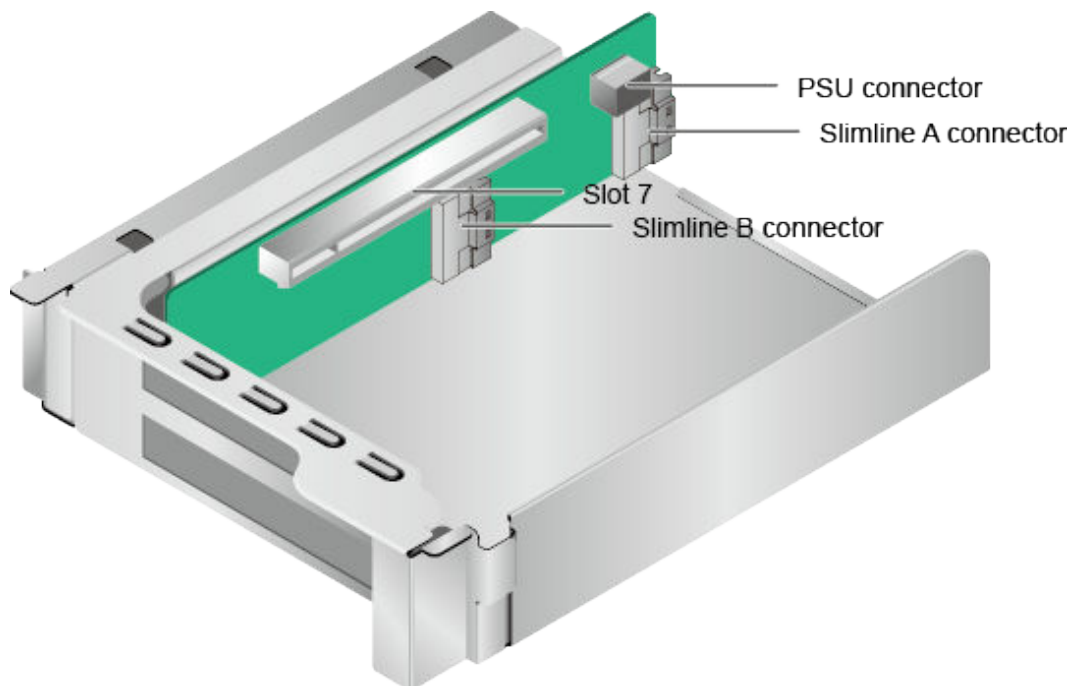


When installed in I/O module 1, this riser card provides slots 1 to 3. When installed in I/O module 2, this riser card provides slots 4 to 6.

**Figure 4-20** Riser card 5

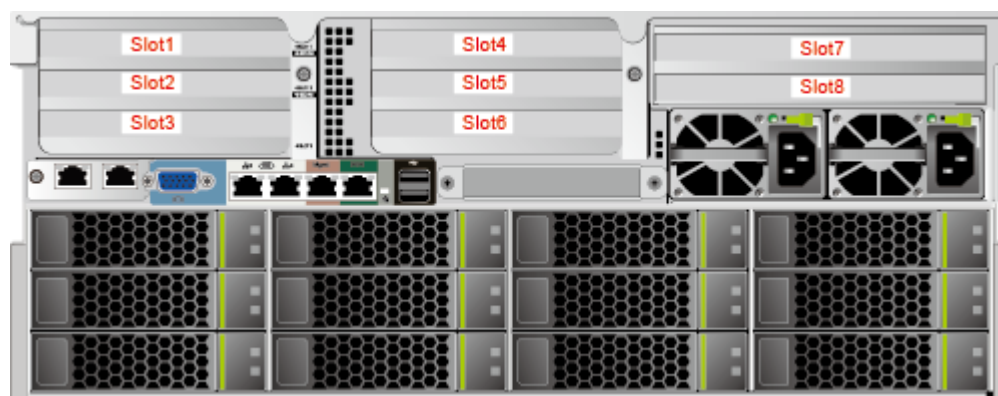


**Figure 4-21** Riser card 6



**Figure 4-22** shows the PCIe slots on the rear panel.

**Figure 4-22** PCIe slots



I/O module 1 provides slots 1 to 3, I/O module 2 provides slots 4 to 6, and I/O module 3 provides slots 7 and 8.

- If I/O module 1 uses a 2-slot PCIe riser module (PRM), slot 2 is unavailable.
- If I/O module 2 uses a 2-slot PRM, slot 5 is unavailable.
- If I/O module 3 uses a 1-slot PRM, slot 8 is unavailable.

**Table 4-11** describes the PCIe slots.

**NOTICE**

If CPU 2 is not installed, the PCIe slots provided by I/O modules 2 and 3 and the flexible NIC are unavailable.

**Table 4-11** PCIe slot description

PCIe Device	CP U	PCIe Standard	Connector Bandwidth	Bus Bandwidth	Port Number	ROOT PORT (B/D/F)	Device (B/D/F)	Slot Size
Slot 1	CP U 1	PCIe 3.0	x16	<ul style="list-style-type: none"> <li>● 2-slot PRM: x16</li> <li>● 3-slot PRM: x8</li> </ul>	Port2A	3A/00/0	3B/00/0	Full-height full-length
Slot 2	CP U 1	PCIe 3.0	x16	<ul style="list-style-type: none"> <li>● 2-slot PRM: N/A</li> <li>● 3-slot PRM: x8</li> </ul>	Port2C	3A/02/0	3D/00/0	<ul style="list-style-type: none"> <li>● 2-slot PRM: N/A</li> <li>● 3-slot PRM: full-height full-length</li> </ul>
Slot 3	CP U 1	PCIe 3.0	x16	x8	Port3A	5D/00/0	5E/00/0	Full-height half-length
Slot 4	CP U 2	PCIe 3.0	x16	<ul style="list-style-type: none"> <li>● 2-slot PRM: x16</li> <li>● 3-slot PRM: x8</li> </ul>	Port1A	85/00/0	86/00/0	Full-height full-length
Slot 5	CP U 2	PCIe 3.0	x16	<ul style="list-style-type: none"> <li>● 2-slot PRM: N/A</li> <li>● 3-slot PRM: x8</li> </ul>	Port1C	85/02/0	89/00/0	<ul style="list-style-type: none"> <li>● 2-slot PRM: N/A</li> <li>● 3-slot PRM: full-height full-length</li> </ul>
Slot 6	CP U 2	PCIe 3.0	x16	x8	Port2C	AE/02/0	B2/00/0	Full-height half-length

PCI e Device	CP U	PCI e Standard	Co nne ctor Band width	Bus Bandwidth	Port Number	ROOT PORT (B/D/F )	Device (B/D/F )	Slot Size
Slot 7	CP U 2	PCI e 3.0	x16	<ul style="list-style-type: none"> <li>● 1-slot PRM: x16</li> <li>● 2-slot PRM: x8</li> </ul>	Port3A	D7/00/0	D8/00/0	Half-height half-length
Slot 8	CP U 2	PCI e 3.0	x8	<ul style="list-style-type: none"> <li>● 1-slot PRM: N/A</li> <li>● 2-slot PRM: x8</li> </ul>	Port3C	D7/02/0	DB/00/0	Half-height half-length
RAI D cont roller card	CP U 1	PCI e 3.0	x8	x8	Port1C	17/02/0	1C/00/0	-
Flex ible NIC	CP U 2	PCI e 3.0	x8	x8	Port2A	AE/00/0	AF/00/0	-
LO M	CP U1	PCI e3.0	x8	x8	Port1A	17/00/0	1A/00/0	-

**NOTE**

- B/D/F, Bus/Device/Function Number.
- **ROOT PORT (B/D/F)** indicates the B/D/F of a CPU internal PCIe root port. **Device (B/D/F)** indicates the B/D/F (displayed on the OS) of an LOM or external PCIe port.
- The PCIe slots that support full-height full-length PCIe cards are backwards compatible with full-height half-length or half-height half-length PCIe cards.
- The PCIe slots that support PCIe x16 cards are backwards compatible with PCIe x8, PCIe x4, and PCIe x1 cards.
- 
- [Table 4-11](#) lists the default values of **B/D/F**. If CPUs are not in full configuration or a PCIe card with a PCI bridge is configured, the values of **B/D/F** may differ.
- The BIOS of the V5 platform uses the UEFI mode by default. If the legacy mode is used, ensure that the sum of option ROMs of all PCIe devices does not exceed the upper limit (128 KB) specified by Intel. Otherwise, some PCIe devices may become unavailable.

## PCIe GPU Configuration Rules

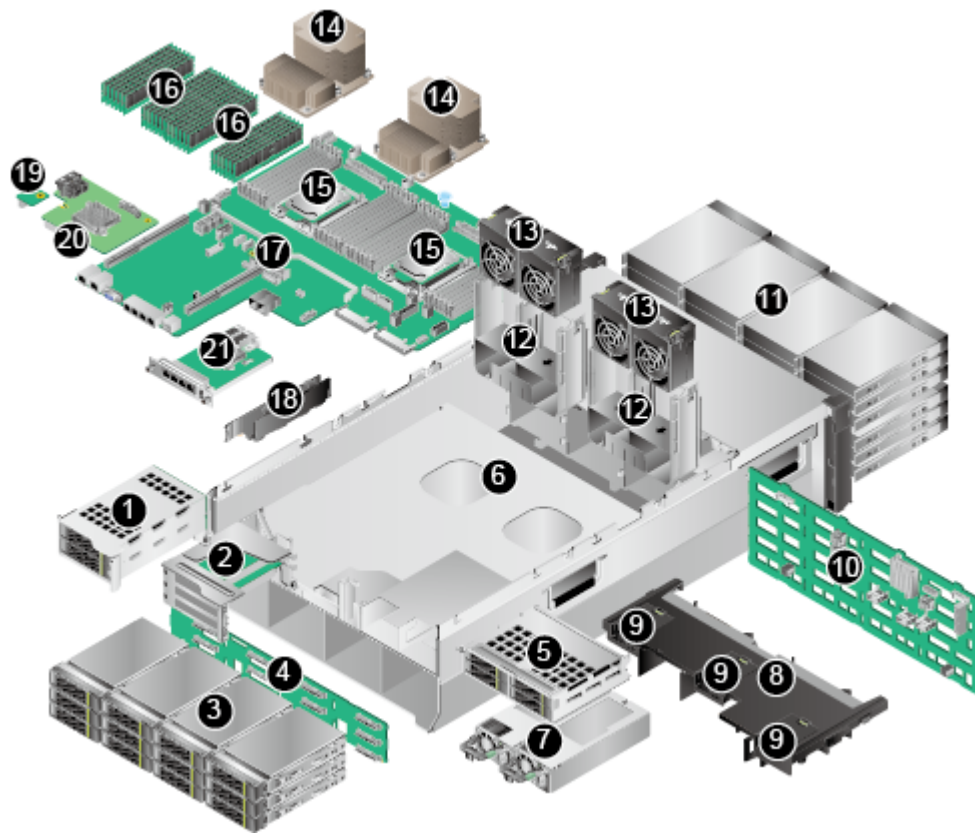
- The 5288 V5 supports only P4 GPU cards of x8 width.
- P4 GPU cards must be installed in I/O module 1 or I/O module 2, which is a riser module with three slots.



- When six P4 GPU cards are configured, the CPU power consumption must be less than 130 W. In case of stack installation, the maximum operating temperature can be 30°C. In case of non-stack installation, the maximum operating temperature can be 35°C.
- When four P4 GPU cards are configured, the P4 GPU cards can be installed in slots 1, 2, 4, and 5. The CPU TDP can be 205 W. In case of stack installation, the maximum operating temperature can be 30°C. In case of non-stack installation, the maximum operating temperature can be 35°C.

## 4.5 Physical Structure

Figure 4-23 Physical structure



1	I/O module 1	2	I/O module 2
3	Rear drives	4	Rear drive backplane
5	I/O module 3	6	Chassis
7	PSUs	8	Air duct
9	Supercapacitors	10	Front drive backplane
11	Front drive	12	Fan module bracket
13	Fan modules	14	Heat sinks
15	CPUs	16	DIMMs
17	Mainboard	18	Cable guide

19	TPM/TCM	20	RAID controller card
21	Flexible NIC (optional)	-	-

# 5 Product Specifications

## 5.1 Technical Specifications

### 5.2 Physical and Environmental Specifications

## 5.1 Technical Specifications

**Table 5-1** Technical specifications

Item	Specifications
Form factor	4U rack server
CPU	One or two Intel® Xeon® Scalable 3100, 4100, 5100, 6100, and 8100 processors <ul style="list-style-type: none"><li>● A maximum of 28 cores (2.5 GHz)</li><li>● Maximum frequency: 3.6 GHz (four cores)</li><li>● Two UPI links: 10.4 GT/s</li><li>● Minimum L3 cache capacity per core: 1.375 MB</li><li>● Maximum thermal design power (TDP): 205 W</li></ul>
Chipset	Intel C622

Item	Specifications
Memory	<ul style="list-style-type: none"> <li>● A maximum of 24 DDR4 RDIMMs or LRDIMMs</li> <li>● RDIMM: twenty-four 32 GB RDIMMs for two CPUs, with a maximum memory capacity of 768 GB</li> <li>● LRDIMM: twenty-four 64 GB LRDIMMs for two CPUs, with a maximum memory capacity of 1536 GB</li> <li>● LRDIMM: twenty-four 128 GB LRDIMMs for two CPUs, with a maximum memory capacity of 3072 GB</li> <li>● Maximum memory speed: 2666 MT/s</li> <li>● Memory protection: Error Checking and Correcting (ECC), Mirrored Channel Mode, Single Device Data Correction (SDDC), Rank Sparring Mode, and Lockstep</li> </ul> <p><b>NOTE</b> DIMMs on one server must be of the same model, type ((RDIMM or LRDIMM), and specifications (capacity, bit width, number of ranks, and height).</p>
Storage	<ul style="list-style-type: none"> <li>● Supports various drive configurations. For details, see <a href="#">Table 6-4</a>.</li> <li>● Supports two M.2 SSD modules.</li> </ul> <p><b>NOTE</b></p> <ul style="list-style-type: none"> <li>● An M.2 SSD is designed only for installing a Linux OS and functions as a boot device. Small-capacity M.2 SSDs (such as 32 GB or 64 GB SSDs) have short endurance and do not support logging. If a small-capacity M.2 SSD is used as the boot device, a dedicated log drive or log server is required for logging. For example: You can dump VMware logs in either of the following ways:             <ol style="list-style-type: none"> <li>1. Redirect /scratch. For details, visit <a href="https://kb.vmware.com/s/article/1033696">https://kb.vmware.com/s/article/1033696</a>.</li> <li>2. Configure syslog. For details, visit <a href="https://kb.vmware.com/s/article/2003322">https://kb.vmware.com/s/article/2003322</a>.</li> </ol> </li> <li>● M.2 SSDs have short endurance and cannot be used as data storage devices. M.2 SSDs have write-through risks in a short time, and cannot be used in frequent data erase operations. SSDs or HDDs with enterprise-level high DWPD can be used for data storage.</li> <li>● Installing write-intensive service software on M.2 SSDs will accelerate the write life consumption and result in perpetual damage of M.2 SSDs. Therefore, M.2 SSDs cannot be used for such services.</li> <li>● M.2 SSDs cannot be used in cache scenarios.</li> </ul> <ul style="list-style-type: none"> <li>● Supports drive hot swap.</li> <li>● Supports RAID 0, 1, 10, 1E, 5, 50, 6, and 60, provides a supercapacitor to protect cache data from power failures, and supports RAID level migration, drive roaming, self-diagnosis, and web-based configuration.</li> <li>● Allows a SAS card or SAS RAID controller card (with a maximum of 4 GB cache) to be configured on the mainboard to improve drive storage performance and ensure user data security.</li> </ul> <p><b>NOTE</b> If the BIOS is in Legacy mode, the server does not support a 4K drive as the system boot disk.</p>

Item	Specifications
Network port	<p>The server has two types of mainboards. One mainboard integrates a LOM chip that provides two 10GE electrical ports and two GE electrical ports. The other motherboard integrates a LOM chip that provides two 10GE optical ports and two GE electrical ports.</p> <p><b>NOTE</b></p> <ul style="list-style-type: none"> <li>● Two 10GE electrical or optical LOM ports (provided by the PCH), supporting NC-SI, WOL, and PXE</li> <li>● Two GE electrical LOM ports (provided by the PCH), supporting NC-SI, WOL, and PXE</li> <li>● The flexible NICs provide the following network ports: <ul style="list-style-type: none"> <li>● Two GE electrical ports, supporting NC-SI, WOL, and PXE</li> <li>● Four GE electrical ports, supporting NC-SI, WOL, and PXE</li> <li>● Two 10GE electrical ports, supporting NC-SI, WOL, and PXE</li> <li>● One 56G IB optical port, not supporting NC-SI, WOL, or PXE</li> <li>● Two 56G IB optical ports, not supporting NC-SI, WOL, or PXE</li> <li>● Two 25GE optical ports, supporting NC-SI, WOL, and PXE</li> </ul> </li> </ul> <p><b>NOTE</b></p> <ul style="list-style-type: none"> <li>● The LOM chip is X722. The 10GE electrical ports and GE electrical ports provided by the LOM do not support interconnection with the PoE power supply device (for example, the PoE switch with the POE function enabled). If such a LOM is forcibly connected, the link communication may be abnormal or the LOM may be damaged.</li> <li>● The electrical ports of the flexible NICs do not support interconnection with the PoE power supply device (for example, the PoE switch with the POE function enabled). If such a NIC is forcibly connected, the link communication may be abnormal or the NIC may be damaged.</li> <li>● If a server is forcibly powered off, the NC-SI function of LOM ports will be unavailable and you need to refresh the iBMC WebUI to restore the function. The WOL function will also be unavailable.</li> </ul>

Item	Specifications
RAID controller card	<p>The RAID controller card does not occupy a standard PCIe slot, which improves system scalability.</p> <p>The RAID controller card supports RAID level migration and drive roaming. The server supports the following RAID controller cards:</p> <ul style="list-style-type: none"> <li>● LSI SAS3008 (SR130): supports RAID 0, 1, 10, and 1E, and does not support out-of-band iBMC management.</li> <li>● LSI SAS3008 (SR130-M): supports the IT mode and iBMC out-of-band management, but does not support RAID arrays.</li> <li>● LSI SAS3108 (SR430C-M): supports RAID 0, 1, 10, 5, 50, 6, and 60, supports a supercapacitor for power-off protection, and support out-of-band iBMC management.</li> <li>● Broadcom SAS3508 (SR450C-M 2G/4G): supports RAID 0, 1, 10, 5, 50, 6, and 60, a supercapacitor for power-off protection, and out-of-band iBMC management.</li> <li>● Broadcom SAS3408 (SR150-M): supports RAID 0, 1, and 10, and out-of-band iBMC management, but does not support power-off protection.</li> <li>● Broadcom SAS3416 (SR760-M): supports RAID 0, 1, and 10, and out-of-band iBMC management, but does not support power-off protection.</li> <li>● Broadcom SAS3416 (SR760IT-M): supports the IT mode and out-of-band iBMC management, and does not support RAID arrays.</li> </ul>

Item	Specifications
PCIe slot	<ul style="list-style-type: none"> <li>● Ten PCIe 3.0 slots, among which one is a dedicated PCIe slot for a RAID controller card, one is a dedicated PCIe slot for a flexible NIC, and the other eight are standard PCIe slots. The specifications of the standard PCIe slots are as follows: I/O modules 1 and 2 provide the following PCIe slots: <ul style="list-style-type: none"> <li>- Two standard full-height full-length PCIe 3.0 x16 slots (bandwidth: PCIe 3.0 x8) and one standard full-height half-length PCIe 3.0 x16 slot (bandwidth: PCIe 3.0 x8)</li> <li>- One standard full-height full-length PCIe 3.0 x16 slot and one standard full-height half-length PCIe 3.0 x16 slot (bandwidth: PCIe 3.0 x8)</li> </ul> </li> <li>I/O module 3 provides the following PCIe slots: <ul style="list-style-type: none"> <li>- One standard half-height half-length PCIe 3.0 x16 slot (bandwidth: PCIe 3.0 x8) and one standard half-height half-length PCIe 3.0 x8 slot</li> <li>- One standard half-height half-length PCIe 3.0 x16 slot</li> </ul> </li> <li>● One Huawei SSD card, which greatly improves I/O performance for search, cache, and download services</li> </ul> <p><b>NOTE</b></p> <ul style="list-style-type: none"> <li>● Use the <a href="#">Huawei Server Compatibility Checker</a> to check the PCIe cards supported by the server. For PCIe cards not listed in the <a href="#">Huawei Server Compatibility Checker</a>, contact your local Huawei sales representative or Huawei technical support.</li> <li>● The BIOS of the V5 platform uses the UEFI mode by default. If the legacy mode is used, ensure that the sum of option ROMs of all PCIe devices does not exceed the upper limit (128 KB) specified by Intel. Otherwise, some PCIe devices may become unavailable.</li> </ul>
Port	<ul style="list-style-type: none"> <li>● The front panel provides two USB 2.0 ports.</li> <li>● Two USB 3.0 ports, one DB15 VGA port, one RJ45 serial port, one system management port, two GE electrical ports, and two 10GE electrical ports or two 10GE optical ports on the rear panel</li> <li>● One built-in USB 3.0 port and two built-in SATA ports</li> </ul> <p><b>NOTE</b> USB port cannot be used for installing OSs.</p>
Fan module	<p>Four hot-swappable fan modules, allowing one-fan failures</p> <p><b>NOTE</b> The fans on one server must be of the same model.</p>

Item	Specifications
System management	<ul style="list-style-type: none"> <li>● UEFI</li> <li>● iBMC Uses an independent port. Supports SNMPv1/SNMPv2c/SNMPv3 and IMPI 2.0, and Redfish 1.0, and provides the GUI, virtual KVM, virtual media, Serial Over LAN (SOL), intelligent power supply, remote control, and hardware monitoring features.</li> <li>● NC-SI</li> <li>● Supports Huawei eSight management software and integration with third-party management systems, such as VMware vCenter, Microsoft SystemCenter, and Nagios.</li> </ul>
Security	<ul style="list-style-type: none"> <li>● Power-on password</li> <li>● Administrator password</li> <li>● TPM (available in and out of China)/TCM (available only in China)</li> <li>● Front bezel (optional) The front bezel is installed on the front panel and comes with a security lock to prevent unauthorized operations on drives.</li> </ul>
Video card	<p>Integrates an SM750 graphics card chip to the mainboard to provide a memory capacity of 32 MB and support a maximum resolution of 1920 x 1200 at 60 Hz with 16 M colors.</p> <p><b>NOTE</b> The maximum resolution 1920 x 1200 is supported only when a compatible graphics card driver is installed. Otherwise, only the default resolution supported by the OS is available.</p>

## 5.2 Physical and Environmental Specifications

### Physical Specifications

**Table 5-2** Physical specifications

Item	Specifications
Dimensions (H x W x D)	175 mm x 447 mm x 748 mm (6.89 in. x 17.60 in. x 29.45 in.)



Item	Specifications
Installation space	<p>The server fits into a universal cabinet that complies with the IEC 297 standard.</p> <ul style="list-style-type: none"> <li>● Cabinet width: 19 in.</li> <li>● Cabinet depth: ≥ 1000 mm (39.37 in.)</li> </ul> <p>Requirements for guide rail installation:</p> <ul style="list-style-type: none"> <li>● L-shaped guide rails: apply only to a Huawei cabinet.</li> <li>● Adjustable guide rails: apply to a cabinet with a distance of 543.5 mm to 848.5 mm (21.40 in. to 33.41 in.) between the front and rear mounting bars.</li> <li>● Holding rails: apply to a cabinet with a distance of 610 mm to 914 mm (24.02 in. to 35.98 in.) between the front and rear mounting bars.</li> </ul>
Weight in full configuration	<p>Net weight: 65 kg (143.33 lb) Packaging materials: 5 kg (11.03 lb)</p>
Power consumption	<p>The power consumption varies with the server configuration. Use the <a href="#">Huawei Server Power Calculator</a> to calculate the power consumption.</p>
Acoustic noise	<p>The data listed in the following is the declared A-weighted sound power levels (LWAd) and declared average bystander position A-weighted sound pressure levels (LpAm) when the server is operating in a 23°C (73.4°F) ambient environment. Noise emissions are measured in accordance with ISO 7779 (ECMA 74) and declared in accordance with ISO 9296 (ECMA 109).</p> <ul style="list-style-type: none"> <li>● Idle: <ul style="list-style-type: none"> <li>- LWAd: 6.04Bels</li> <li>- LpAm: 46.0dBA</li> </ul> </li> <li>● Operating: <ul style="list-style-type: none"> <li>- LWAd: 6.51Bels</li> <li>- LpAm: 50.7dBA</li> </ul> </li> </ul> <p><b>NOTE</b> The actual sound levels generated when the server is operating vary depending on the server configuration, workload, and ambient temperature.</p>

## Environmental Specifications

- **Temperature**
  - Operating temperature: 5°C to 40°C (41°F to 104°F) (ASHRAE CLASS A2 and A3 compliant). For details, see [Table 5-3](#).
  - Storage temperature: -40°C to +65°C (-40°F to +149°F).
  - Temperature change rate: < 20°C/h (36°F/h).

**Table 5-3** Operating temperature specifications

Model	Maximum Operating Temperature 30°C (86°F)	Maximum Operating Temperature 35°C (95°F) (ASHRAE CLASS A2 compliant)	Maximum Operating Temperature 40°C (104°F) (ASHRAE CLASS A3 Compliant)
Single RAID controller card (with built-in drives)	Does not support 8180/8168/6154/6151 CPUs.	<ul style="list-style-type: none"> <li>● Does not support drives in I/O modules 1 and 2.</li> <li>● Does not support NVMe SSDs in I/O module 3.</li> <li>● Does not support built-in drives.</li> <li>● Does not support PCIe SSD cards.</li> <li>● Does not support 8180/8168/6154/6151 CPUs.</li> </ul>	<ul style="list-style-type: none"> <li>● Does not support drives in I/O modules 1 and 2.</li> <li>● Does not support NVMe SSDs in I/O module 3.</li> <li>● Does not support PCIe SSD cards.</li> <li>● Supports only 8153/6152/6140/6126/5118 CPUs and CPUs with a power consumption lower than 105 W.</li> </ul>
Single RAID controller card (no built-in drives)	Supports all configurations.	<ul style="list-style-type: none"> <li>● Does not support drives in I/O modules 1 and 2.</li> <li>● Does not support NVMe SSDs in I/O module 3.</li> <li>● Does not support built-in drives.</li> <li>● Does not support PCIe SSD cards.</li> </ul>	<ul style="list-style-type: none"> <li>● Does not support drives in I/O modules 1 and 2.</li> <li>● Does not support NVMe SSDs in I/O module 3.</li> <li>● Does not support built-in drives.</li> <li>● Does not support NVMe SSDs in slots 32 to 35.</li> <li>● Does not support PCIe SSD cards.</li> <li>● Does not support</li> </ul>

Model	Maximum Operating Temperature 30°C (86°F)	Maximum Operating Temperature 35°C (95°F) (ASHRAE CLASS A2 compliant)	Maximum Operating Temperature 40°C (104°F) (ASHRAE CLASS A3 Compliant)
Dual RAID controller cards			8180/8168/6154/6151/6144/6146 CPUs.
<p><b>NOTE</b></p> <ul style="list-style-type: none"> <li>● If one fan fails, the highest operating temperature of the server is 5°C lower than that in normal cases.</li> <li>● If rear NVMe SSDs are configured, the failure of a single fan can affect the drive performance.</li> <li>● When six P4 GPU cards are configured, the CPU power consumption must be less than 130 W. In case of stack installation, the maximum operating temperature can be 30°C. In case of non-stack installation, the maximum operating temperature can be 35°C.</li> <li>● When four P4 GPU cards are configured, the P4 GPU cards can be installed in slots 1, 2, 4, and 5. The CPU TDP can be 205 W. In case of stack installation, the maximum operating temperature can be 30°C. In case of non-stack installation, the maximum operating temperature can be 35°C.</li> </ul>			

- **Humidity**
  - Operating humidity: 8% RH to 90% RH (non-condensing)
  - Storage humidity: 5% to 95% RH (non-condensing)
  - Humidity change rate: < 20% RH/h
- **Air volume**  
273 CFM
- **Altitude**
  - ≤3050 m (10006.44 ft). According to the ASHRAE standards of 2015, for altitudes above 950 m (3116.79 ft), the highest operating temperature decreases by 1°C (1.8°F) for every increase of:
    - 300 m (984.24 ft) in altitude when the server configuration complies with Class A2 standards.
    - 175 m (575.14 ft) in altitude when the server configuration complies with Class A3 standards.
  - HDDs are not supported when the altitude is higher than 3000 m (9842.4 ft).
- **Corrosive gaseous contaminant**
  - Copper corrosion rate test requirements: The corrosion product thickness growth rate is lower than 300 Å/month (meeting level G1 requirements of the ANSI/ISA-71.04-2013 standard on gaseous corrosion).
  - Silver corrosion rate test requirements: The corrosion product thickness growth rate is lower than 200 Å/month.
- **Particle contaminant**
  - The equipment room environment meets the requirements of ISO 14664-1 Class 8.

You are advised to hire a professional organization to monitor particle contaminants in the equipment room.

- The equipment room is free from explosive, conductive, magnetic conductive, and corrosive dust.

# 6 Component Compatibility

---

Use the [Huawei Server Compatibility Checker](#) to check the software and hardware supported by the server.

[6.1 CPU](#)

[6.2 Memory](#)

[6.3 Storage](#)

[6.4 I/O Expansion](#)

[6.5 PSU](#)

[6.6 OS and Software Support](#)

## 6.1 CPU

One or two Intel® Xeon® Scalable 3100, 4100, 5100, 6100, and 8100 processors

- A maximum of 28 cores (2.5 GHz)
- Maximum frequency: 3.6 GHz (four cores)
- Two UPI links: 10.4 GT/s
- Minimum L3 cache capacity per core: 1.375 MB
- Maximum thermal design power (TDP): 205 W

### NOTE

- For details about component options, consult the local Huawei sales representatives.
- CPUs on the same server must be of the same model.
- For details about CPUs, visit <https://www.intel.com/content/www/us/en/homepage.html>.

## 6.2 Memory

### Memory Configuration Rules

A server provides 24 DDR4 DIMM slots. Each processor supports six memory channels and each memory channel supports two DDR4 DIMMs.

Observe the following rules when configuring DIMMs:

1. DIMMs of different types (RDIMMs and LRDIMMs) cannot be installed on one server.
2. Each channel supports a maximum of eight ranks.

 **NOTE**

A channel supports more than eight ranks for LRDIMMs, because a quad-rank LRDIMM generates the same electrical load as a single-rank RDIMM on a memory bus.

3. The maximum number of DIMMs to be installed on the server varies with the processor type, DIMM type, number of ranks, and operating voltage. For details, see **Maximum number of DIMMs** in the following tables.

 **NOTE**

Restriction of the number of ranks supported by each channel on the maximum number of DIMMs supported by each channel:

Number of DIMMs supported by each channel ≤ Number of ranks supported by each memory channel/Number of ranks supported by each DIMM

4. All DIMMs operate at the same speed, which is the smaller value of:
  - Memory speed supported by a CPU
  - Lowest maximum operating speed for the selected memory configuration. For details, see **Maximum operating speed** in the following tables.

**Table 6-1** RDIMM configuration

Item		Specifications
Rank		Dual-rank
Rated speed (MT/s)		2666
Operating voltage (V)		1.2
Maximum number of DIMMs		24
Maximum capacity per DIMM (GB)		32
Maximum total memory capacity (GB)		768
Maximum total memory capacity at maximum operating speed (GB)		768
Maximum operating speed (MT/s)	One DIMM per channel	2666
	Two DIMMs per channel	2666
Note: The maximum number of DIMMs listed in this table is based on dual-processor configuration. These values are halved for a server with only one processor.		

**Table 6-2** LRDIMM configuration

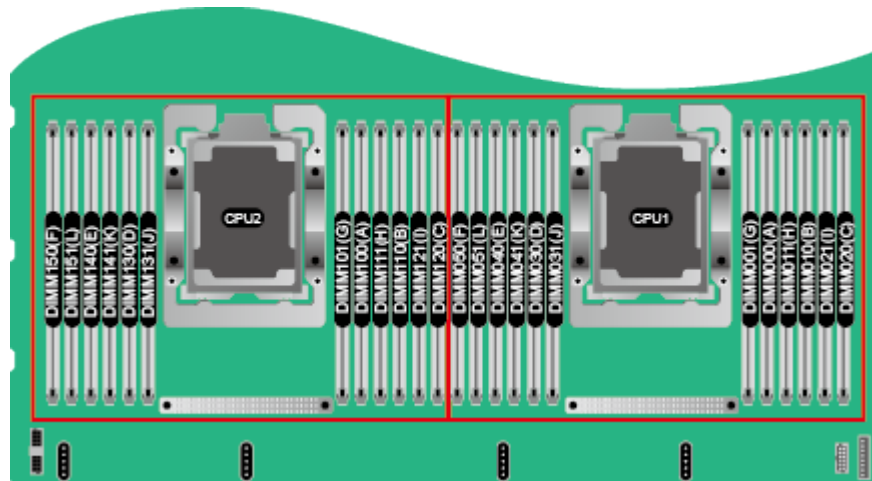
Item		Specifications
Rank		Quad-rank

Item		Specifications
Rated speed (MT/s)		2666
Operating voltage (V)		1.2
Maximum number of DIMMs		24
Maximum capacity per DIMM (GB)		128
Maximum memory capacity (GB)		3072
Maximum total memory capacity at maximum operating speed (GB)		3072
Maximum operating speed (MT/s)	One DIMM per channel	2666
	Two DIMMs per channel	2666
Note: The maximum number of DIMMs listed in this table is based on dual-processor configuration. These values are halved for a server with only one processor.		

## Memory Slot Configuration Rules

Figure 6-1 shows the DIMM slot numbers and positions.

Figure 6-1 DIMM slots



- The server supports DIMMs of 8 GB, 16 GB, 32 GB, 64 GB, and 128 GB. A server fully configured with DIMMs provides up to 3072 GB memory.
- The server provides 24 DDR4 DIMM slots. Each CPU supports six channels. [Table 6-3](#) lists channels for each CPU.

**Table 6-3** Channels

CPU	Channel	DIMM	
CPU 1	A	DIMM000(A)	
		DIMM001(G)	
	B	DIMM010(B)	
		DIMM011(H)	
	C	DIMM020(C)	
		DIMM021(I)	
	D	DIMM030(D)	
		DIMM031(J)	
	E	DIMM040(E)	
		DIMM041(K)	
	F	DIMM050(F)	
		DIMM051(L)	
	CPU2	A	DIMM100(A)
			DIMM101(G)
B		DIMM110(B)	
		DIMM111(H)	
C		DIMM120(C)	
		DIMM121(I)	
D		DIMM130(D)	
		DIMM131(J)	
E		DIMM140(E)	
		DIMM141(K)	
F		DIMM150(F)	
		DIMM151(L)	

## DIMM Installation Rules

**NOTICE**

At least one DIMM must be configured in slots supported by CPU 1.





## Memory Protection Technologies

The server supports the following memory protection technologies:

- ECC
- Mirrored Channel Mode
- SDDC
- Rank Sparing Mode
- Lockstep

## Supported DIMMs

### NOTE

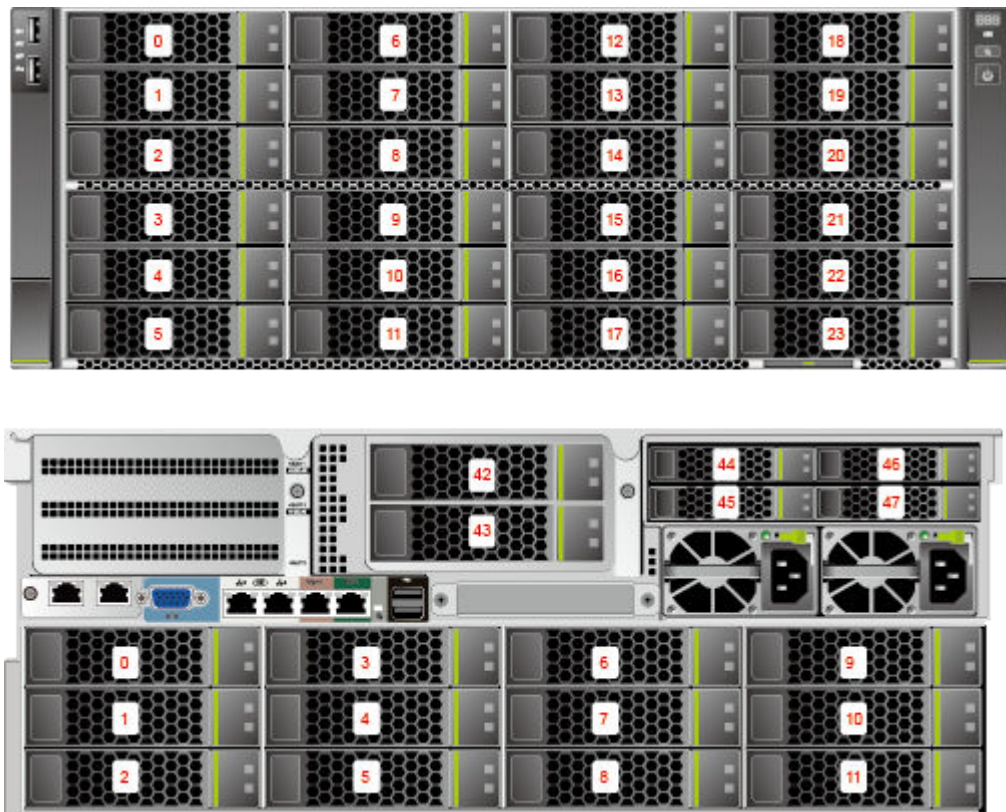
- For details about component options, consult the local Huawei sales representatives.
- DIMMs on one server must be of the same model.

## 6.3 Storage

Figure 6-4 Drive slot layout of a server with one RAID controller card



**Figure 6-5** Drive slot layout of a server with two RAID controller cards



**Table 6-4** lists drive configurations supported by the server.

**NOTE**

The following table is for reference only. For details about component options, consult the local Huawei sales representatives.

**Table 6-4** Drive configurations

Configuration	Maximum Front Drives	Maximum Rear Drives	Maximum Built-in Drives	SATA/SAS Drive Management Mode
Server with one RAID controller card	24 (SAS/SATA drives)	<ol style="list-style-type: none"> <li>1. I/O module 1: 2 (SAS/SATA drives)<sup>[1]</sup></li> <li>2. I/O module 2: 2 (SAS/SATA drives)</li> <li>3. I/O module 3: 4 (SAS/SATA drives or NVMe SSDs)<sup>[4]</sup></li> <li>4. Rear: 12 (SAS/SATA drives or NVMe SSDs)                             <ol style="list-style-type: none"> <li>a. Slots 24 to 31 support only SAS/SATA drives.</li> <li>b. Slots 32 to 35 support SAS/SATA drives and NVMe SSDs.<sup>[5]</sup></li> </ol> </li> </ol>	4 (SATA or SAS drives) <sup>[3]</sup>	One RAID controller card
Two RAID controller cards	24 (SAS/SATA drives)	<ol style="list-style-type: none"> <li>1. I/O module 2: 2 (SAS/SATA drives)</li> <li>2. I/O module 3: 4 (NVMe SSDs)</li> <li>3. Rear: 12 (SAS/SATA drives)</li> </ol>	-	Two RAID controller cards <sup>[2]</sup>
<ul style="list-style-type: none"> <li>● [1]: When NVMe SSDs are installed in slots 32 to 35, I/O module 1 supports only NVMe adapters but does not support drives.</li> <li>● [2]: The 24 drives at the front and the drives in I/O module 2 are controlled by one RAID control card, and the 12 drives at the rear are controlled by the other RAID control card.</li> <li>● [3]: A server with one RAID controller card supports built-in drives only when an SR760-M (Broadcom SAS3416) RAID control card is configured.</li> <li>● [4]: A server with one RAID controller card supports SAS/SATA drives to be installed in I/O module 3 only when an SR760-M (Broadcom SAS3416) RAID control card is configured.</li> <li>● [5]: When built-in drives are installed, slots 32 to 35 on a server with one RAID controller card does not support NVMe SSDs.</li> </ul>				

**Table 6-5** lists the comparison between RAID levels in performance and disk usage.

**Table 6-5** RAID level comparison

RAID Level	Reliability	Read Performance	Write Performance	Drive Usage
RAID 0	Low	High	High	100%
RAID 1	High	High	Low	50%
RAID 5	Relatively high	High	Medium	$(N - 1)/N$
RAID 6	Relatively high	High	Medium	$(N - 2)/N$
RAID 10	High	High	Medium	50%
RAID 1E	High	Medium	Medium	50%
RAID 50	High	High	Relatively high	$(N - M)/N$
RAID 60	High	High	Relatively high	$(N - M \times 2)/N$
Note: N indicates the number of member disks in a RAID array, and M indicates the number of spans in a RAID array.				

## 6.4 I/O Expansion

The server supports a wide range of PCIe cards for you to choose based on the card type and transmission speed:

- Fiber Channel (FC) host bus adapter (HBA)
- Converged network adapter (CNA)
- Network expansion card
- SSD card

### NOTE

For details about component options, consult the local Huawei sales representatives.

## 6.5 PSU

**Table 6-6** lists the PSUs supported by the server.

**Table 6-6** Supported PSUs

PSU Model	Rated Power	Rated Input Voltage
900 W AC Platinum PSU	900 W	<ul style="list-style-type: none"> <li>● AC: 100 V to 240 V</li> <li>● HVDC: 192 V to 288 V</li> </ul>
1500 W AC Platinum PSU	1500 W	<ul style="list-style-type: none"> <li>● AC: 100 V to 240 V</li> <li>● HVDC: 192 V to 288 V</li> </ul>
1200 W DC PSU	1200 W	DC: -48 V to -60 V

 NOTE

- The PSUs are hot-swappable and work in 1+1 redundancy mode.
- [Table 6-6](#) is for reference only. For details about component options, see the [Huawei Server Compatibility Checker](#).
- PSUs on one server must be of the same model.
- The PSUs provide short-circuit protection. The PSUs that support dual input live wires provide double-pole fuse.
- If the input voltage ranges from 100 V to 132 V AC, the output power of the 1500 W AC platinum PSU decreases to 1000 W.
- The power of a 1500 W AC platinum PSU can reach 1700 W. When two such PSUs are installed, they can be used as 1700 W PSUs.

## 6.6 OS and Software Support

For details about component options, see the [Huawei Server Compatibility Checker](#).

# 7 System Management

The server uses Huawei's proprietary iBMC to implement remote server management. The iBMC complies with IPMI 2.0 and provides highly reliable hardware monitoring and management.

The iBMC supports the following features and protocols:

- KVM and text console redirection
- Remote virtual media
- IPMI
- SNMP
- Redfish 1.0
- Login using a web browser

**Table 7-1** describes the features of the iBMC.

**Table 7-1** iBMC features

Feature	Description
Management interface	Integrates with any standard management system through the following interfaces: <ul style="list-style-type: none"> <li>● IPMI</li> <li>● CLI</li> <li>● HTTPS</li> <li>● SNMP</li> <li>● Redfish</li> </ul>
Fault detection	Detects faults and accurately locates faults in hardware, for example, an FRU.
Alarm management	Supports alarm management and reports alarms using the SNMP trap, Simple Mail Transfer Protocol (SMTP), and syslog service to ensure 24/7 operating.
Integrated virtual KVM	Provides remote maintenance measures for troubleshooting.



Feature	Description
Integrated virtual media	Virtualizes local media devices, images, USB keys, and folders into media devices on a remote server, simplifying OS installation. (The virtual DVD-ROM drive supports a maximum transmission rate of 8 MB/s.)
WebUI	Provides a user-friendly graphical user interface (GUI), which simplifies users' configuration and query operations.
Fault reproduction	Reproduces faults to facilitate fault diagnosis.
Screen snapshots and screen videos	Allows you to view screenshots and videos without login, which facilitates routine preventive maintenance inspection (PMI)
Domain Name Service (DNS)/Active Directory (AD)	Supports the DNS and AD, significantly simplifying network and configuration management.
Dual-image backup	Starts software from a backup image if the software fails.
Asset management	Supports intelligent asset management.
Intelligent power management	Uses the power capping technology to increase deployment density, and uses dynamic energy saving to lower operating expenses.
IPv6	Supports IPv6 to ensure sufficient IP addresses.
Network Controller Sideband Interface (NC-SI)	Supports NC-SI, which allows you to access the iBMC through the service network port.

---

# 8 Warranty

---

According to the *Huawei Warranty Policy for Servers & Storage Products* (*Warranty Policy* for short), Huawei provides a three-year warranty for the server, a one-year warranty for DVD-RW drives and batteries, and a three-month warranty for software media.

The *Warranty Policy* stipulates warranty terms and conditions, including the available services, response time, terms of service, and disclaimer.

The warranty terms and conditions may vary by country, and some services and/or parts may not be available in all countries. For more information about warranty services in your country, contact Huawei technical support or a local Huawei representative office.

# 9 Certifications

Country/Region	Certification	Standards
Europe	WEEE	2002/96/EC, 2012/19/EU
Europe	RoHS	2002/95/EC, 2011/65/EU, EN 50581:2012
Europe	REACH	EC NO. 1907/2006
Europe	CE	Safety: EN 60950-1:2006+A11:2009+A1:2010+A12:2011 EMC: <ul style="list-style-type: none"> <li>● EN 55022:2010</li> <li>● CISPR 22:2008</li> <li>● EN 55024:2010</li> <li>● CISPR 24:2010</li> <li>● ETSI EN 300 386 V1.6.1:2012</li> <li>● ETSI ES 201 468 V1.3.1:2005</li> </ul>
China	CCC	GB4943.1-2011 GB9254-2008 (Class A) GB17625.1-2012
China	RoHS	SJ/T-11363-20006 SJ/T-11364-20006 GB/T 26572-2011
Australia	C-tick	AS/NZS CISPR22:2009
America	FCC	FCC Part 15 (Class A)

Country/Region	Certification	Standards
America	NTRL-UL	UL 60950-1, 2nd Edition, 2011-12-19 (Information Technology Equipment - Safety - Part 1: General Requirements) CSA C22.2 No.60950-1-07, 2nd Edition, 2011-12 (Information Technology Equipment-Safety-Part 1: General Requirements)
Canada	IC	ICES-003 Class A
Canada	NRTL-UL	UL 60950-1, 2 <sup>nd</sup> Edition, 2011-12-19 (Information Technology Equipment-Safety-Part 1: General Requirements)
Nigeria	SONCAP	IEC 60950-1: 2005 (2nd Edition) + A1:2009 EN 60950-1:2006+A11:2009+A1:2010 + A12:2011
Kingdom of Saudi Arabia (KSA)	SASO	IEC 60950-1: 2005 (2nd Edition) + A1:2009 EN 60950-1:2006+A11:2009+A1:2010 + A12:2011
Global	CB	IEC 60950-1
Japan	VCCI	VCCI V-4:2012
Saudi, Nigeria, Tanzania, Uganda, Kuwait, Algeria, Botswana, Qatar, Egypt	Multi-country_certificate	IEC 60950-1: 2005 (2nd Edition) + A1:2009 EN 60950-1:2006+A11:2009+A1:2010 + A12:2011

# 10 References

---

For more information about the product, see the following documents:

- [Server Data Sheet](#)
- [Server Documentation](#)
- [Huawei Server Information Self-Service Platform](#)